

ALLSAFE LIFTING

MODULAR 1 TONNE LIFTING BEAM USER MANUAL

REVISION: 1

REPORT No.:	EA -1644-002	CLIENT:	ALLSAFE LIFTING
PO No:	00023023		
TITLE:	MODULAR 1 TONNE LIFTING BEAM USER MANUAL		

DESIGNER APPROVAL		CUSTOMER ACCEPTANCE	
Signature	<i>J w Butler</i>	Signature	
Full Name	John Butler	Full Name	
Title / Rank	Principal Naval Architect	Title / Rank	
Organisation	John Butler Design	Organisation	
Date	31/08/2016	Date	

ENDORSEMENTS & REVISION HISTORY

The document is cleared by:

	Name	Department / Group	Date
Prepared By	Nichola Buchanan	HULL	31/08/2016
Checked By	Carrie Suh	HULL	31/08/2016
Approved By	John Butler	HULL	31/08/2016

RECORD OF AMENDMENTS

Rev No	Date	Description	Prepared By	Checked By	Approved By
1	31/08/2016	Original Issue	Nichola Buchanan	Carrie Suh	John Butler

TABLE OF CONTENTS

1	BACKGROUND	3
2	PURPOSE	3
3	REFERENCES	3
4	ABBREVIATIONS, ACRONYMS AND DEFINITIONS	3
5	GENERAL NOTES.....	3
6	ASSEMBLY OF LIFTING BEAM EXTENSION PIECES.....	4
7	DISASSEMBLY	5
8	STORAGE.....	5
9	SAFETY PRECAUTIONS	5
10	MAINTENANCE SCHEDULE	5
	A) NOTES.....	5
	B) BEFORE USE MAINTENANCE.....	5
	C) AFTER USE MAINTENANCE	5
	D) 6 MONTHLY MAINTENANCE	5
	E) 12 MONTHLY MAINTENANCE	5
11	LIFTING CAPACITY OF MODULAR 1 TONNE LIFTING BEAM	6

1 BACKGROUND

A design proposal for a modular lifting beam was developed. The lifting beam is required to be assembled to varying lengths. Allsafe Lifting requested that an engineering assessment be undertaken on the proposed modular lifting beam design. This included a finite element analysis on the proposed lifting beam structure.

2 PURPOSE

The purpose of this report is to outline the assembly and disassembly steps, inspection schedule and maintenance steps required for the safe operation of the modular 1 tonne lifting beam before use, after use and routinely during the life of the lifting beam.

3 REFERENCES

- a) Allsafe Lifting Purchase Order 00023023, dated 09/08/2016
- b) Email from Troy Sargent (Allsafe Lifting) – “Lifting beams” dated 13/07/2016
- c) JBD Report: EA-1644-001 – Finite Element Analysis of Modular 1T, 5T & 10T Lifting Beams
- d) JBD Drawing: 1644/3-02 – Modular Lifting Beam Construction Drawing

4 ABBREVIATIONS, ACRONYMS AND DEFINITIONS

EA	Engineering Assessment
IAW	In Accordance With
JBD	John Butler Design
SWL	Safe Working Load
WHS	Workplace Health & Safety

5 GENERAL NOTES

The modular lifting beam is to be used only for its designed purpose and under the guidelines set out in this manual.

All bolts are to be tightened to the specifications of the manufacturer. If the bolts, nuts and/or washers require replacement, the replacement part is to be the same as the original item.

The structure is to be inspected for any loose or damaged parts prior to lifting the structure. All welds are to be visually inspected for corrosion, cracking or other defects.

When not in use, the lifting beam and all components are to be disassembled and stored where it will not be exposed to moisture, sunlight or extreme temperatures.

The SWL of lifting slings and attachments are to be greater than the combined mass of the item to be lifted and the length of lifting beam.

For a double point lift, the angles of the lifting slings is not to exceed 60 degrees.

The angle of the lifting slings attached to the item to be lifted is to not exceed 5 degrees.

6 ASSEMBLY OF LIFTING BEAM EXTENSION PIECES

The modular lifting beam is to be assembled as per the procedure outlined below. All bolts are to be hand tightened until the structure is completely assembled. All bolts are to then be tightened IAW with the manufacturers specifications.

1. Place the centre beam on a level surface so that it cannot move during the assembly process.
2. Take the first extension piece and slide into place such that the bolting plate of the centre beam is within the bent bolted plate of the extension piece – see Figure 1.
3. Take four (4) of the M20 bolts and nuts as well as eight (8) washers and fasten the extension piece to the centre beam. All bolts are to be tightened IAW the manufacturers specifications.
4. Take the second extension piece and slide into place as per Step 2. Fasten the extension piece as per Step 3 – see Figure 2.
5. Extension pieces are to be added as per Steps 2 through 4 until the desired lifting length has been reached. The overall length of the lifting beam is not to exceed 10.5 m – see Figure 3.

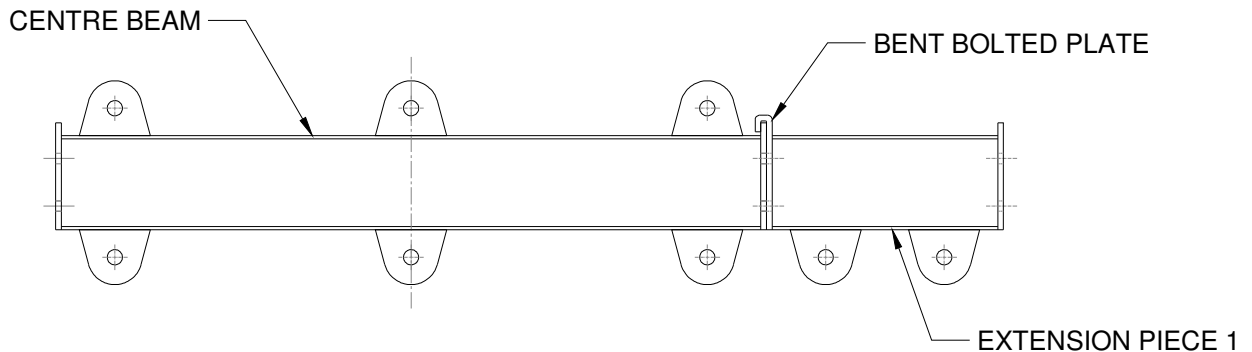

Figure 1 – Extension Piece 1 placed in position

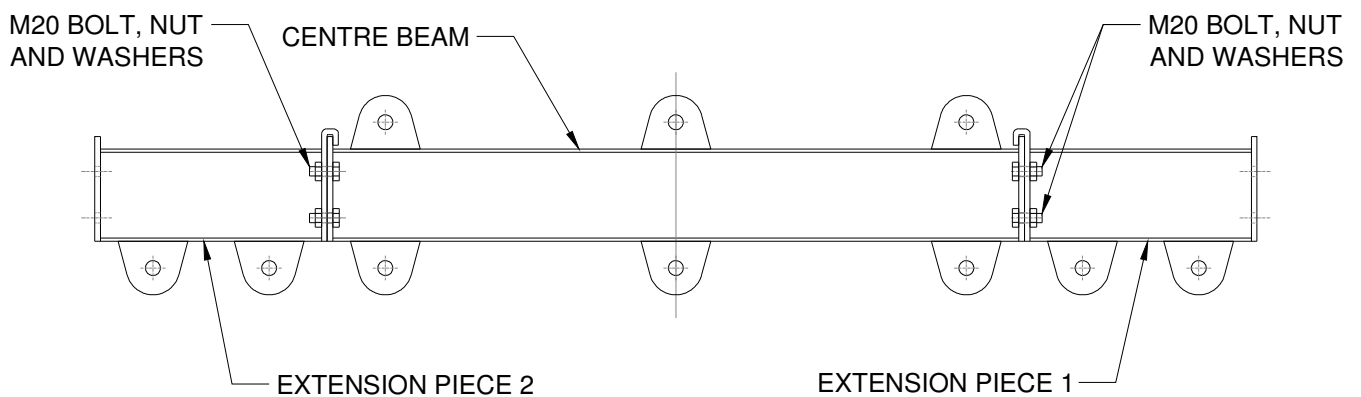

Figure 2 – Extension Pieces 1 and 2 secured to Centre Beam

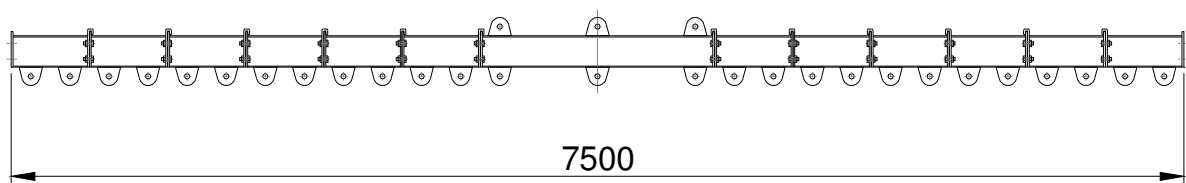

Figure 3 – Maximum Overall length of 1 tonne Lifting Beam

7 DISASSEMBLY

To disassemble the structure, follow the reverse of the steps listed in Section 6.

8 STORAGE

Once the modular lifting beam has been disassembled, it is to be packed and stored such that no damage to the paint coating or structural components may occur. The parts are to be stored such that they do not come in direct contact with other parts or items that are also being stored to prevent damage to the paint coating.

9 SAFETY PRECAUTIONS

- SP 1 Lifting and moving large and/or heavy parts is to be IAW the current WHS legislation.
- SP 2 Prior to lifting, the lifting beam and all components are to be inspected for corrosion, cracking or loose parts. If any defects are found they are to be rectified prior to lifting.

10 MAINTENANCE SCHEDULE

a) NOTES

- N 1 These procedures outline the maintenance and inspection required before and after use.
- N 2 Any defects that are identified are to be rectified before commencement of the next usage.
- N 3 The modular lifting beam is to be disassembled during all 6 month and 12 month maintenance routines.

b) BEFORE USE MAINTENANCE

- BU 1 Check tensions of all bolts.
- BU 3 Check structure for degradation of paint coating.
- BU 4 Check structure for cracks, corrosion and deformation.
- BU 5 Check structure for any loose parts.

c) AFTER USE MAINTENANCE

- AU 1 Visually inspect all items for cracks or deformation.

d) 6 MONTHLY MAINTENANCE

- 6M 1 Visually inspect all bolts and replace as necessary.
- 6M 2 Visually inspect all items for cracks and corrosion.
- 6M 3 Visually inspect all items paint coating and re-paint as necessary.

e) 12 MONTHLY MAINTENANCE

- 12M 1 Visually inspect all bolts and replace as necessary.
- 12M 2 Visually inspect all items for cracks and corrosion.
- 12M 3 Visually inspect all welds for cracks and corrosion.
- 12M 4 Visually inspect all items paint coating and re-paint as necessary.
- 12M 5 Re-certify all lifting points.

11 LIFTING CAPACITY OF MODULAR 1 TONNE LIFTING BEAM

The table below details the lifting capacity of the beam for the allowable assembled lengths. This table is to be read in conjunction with Figures 4, 5 and 6.

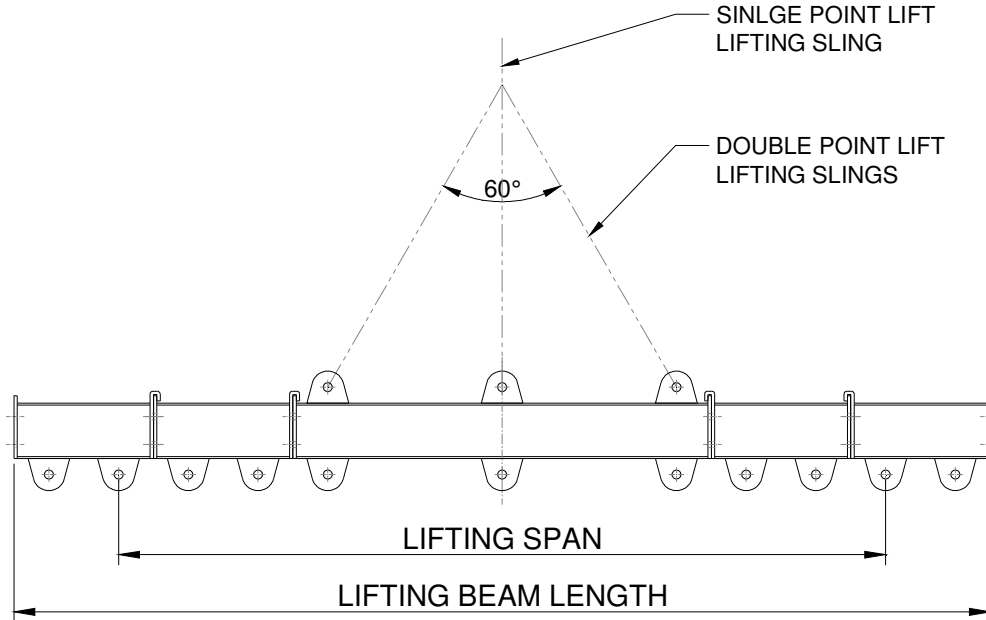

Figure 4 – Typical Lifting Arrangement

Lifting Beam Length	Lifting Span (m)	Single Point Lift (per lug) (t)	Double Point Lift (per lug) (t)
1.5 m	0.00	-	1.00
	1.25	0.50	1.00
2.5 m	1.75	0.50	0.50
	2.25	0.50	0.50
3.5 m	2.75	0.50	0.50
	3.25	0.50	0.50
4.5 m	3.75	0.50	0.50
	4.25	0.50	0.50
5.5 m	4.75	0.50	0.50
	5.25	0.50	0.50
6.5 m	5.75	0.50	0.50
	6.25	0.50	0.50
7.5 m	6.75	0.40	0.40
	7.25	0.40	0.38

Table 1 – Lifting Capacity for each Lifting Beam Length

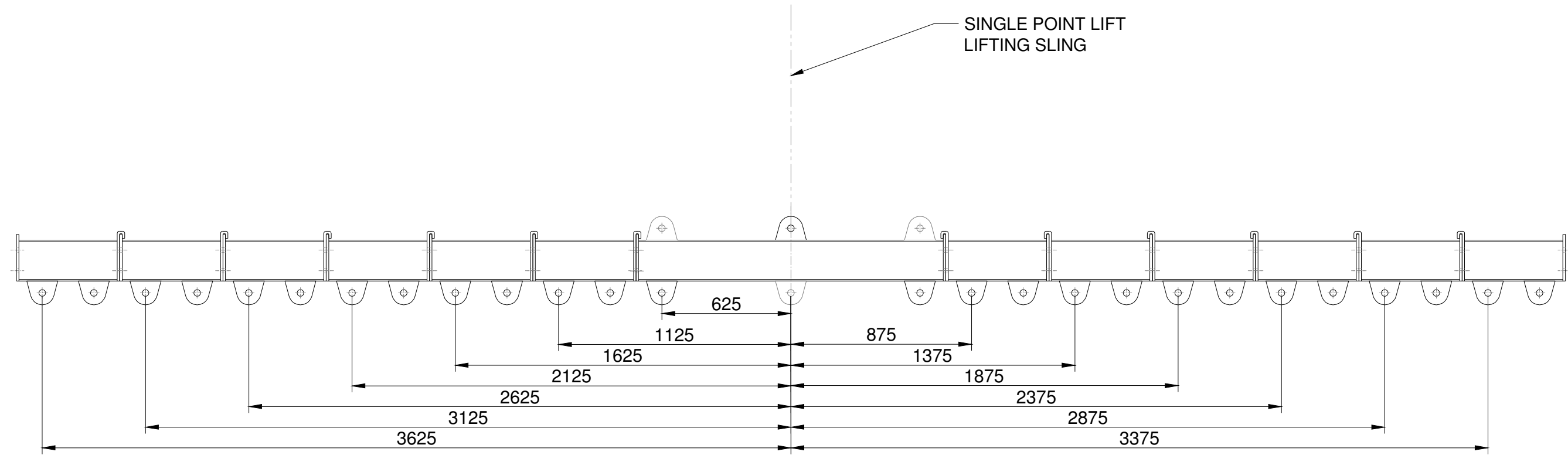

Figure 5 – Lifting Spans for a Single Point Lift

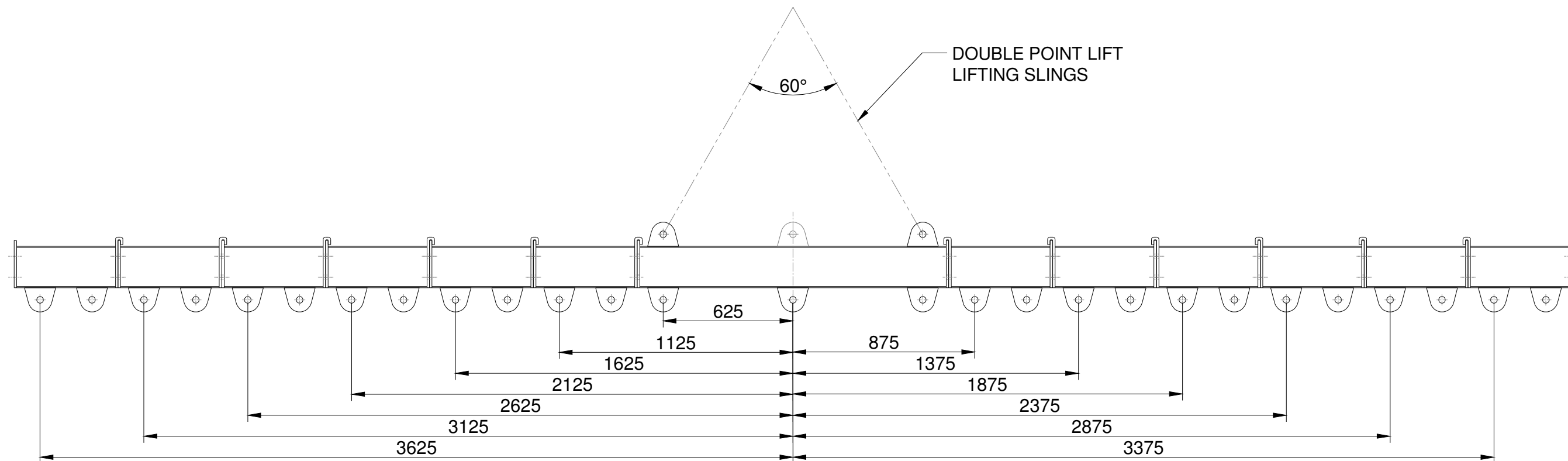

Figure 6 – Lifting Spans for a Double Point Lift